

CeLAN Manual Barrier Controller

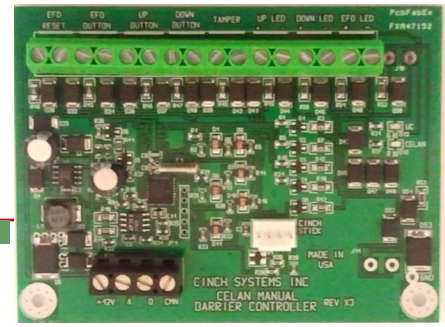

I-Ce-MBC Rev B

Overview:

The CeLAN Manual Barrier Controller is a CeLAN data bus module that wires directly to the Rampart data bus and barrier control buttons. The Ce-MBC mounts in the master controller or remote controller for manual control of barrier operations.

The Ce-MBC provide:

- Up pushbutton
- Down pushbutton
- EFO/Reset Key Switch
- LED status indication

Installation:

The manual modules are installed in the manual button control box. Each module is individually wired to its respective control buttons, LED's and switches

The modules can be mounted on the side or mounted in the bottom of the control box.

Wiring:

The Ce-MBC is wired to the Rampart data bus and must maintain a constant communication with Rampart for proper operation.

Ce-MBC - Manual Barrier Control

4 Inputs

- Reset Switch
- Up Button
- Down Button
- EFO Button
- Tamper (not used)

3 Outputs

- Up LED
- Down LED
- EFO LED

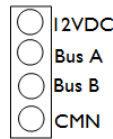
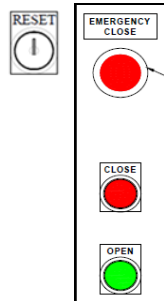

Each module has a data bus header that is wired to the Rampart data bus.

Note: use common colors when wiring data lines to maintain consistency

The

Rampart data bus can be wired in a star, daisy-chain or home-run configuration, it is critical to keep all Bus A and Bus B wires consistent through-out the installation.

The Ce-MBC wires directly to the control box buttons and LED's, the reset switch is used for EFO reset function.

Note: A single Ce-MBC board is used for each individual set of buttons for barrier control

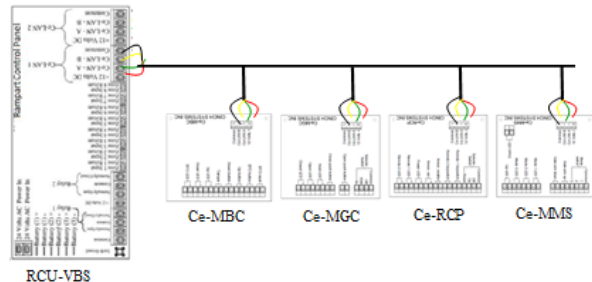

Ce-MBC Wiring:

The Manual Barrier Control has inputs for buttons and outputs for LED's and a reset switch for EFO reset.

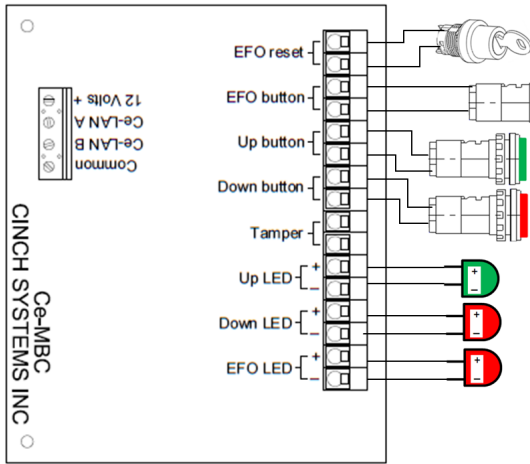

If wiring in a master control box that controls multiple barriers, each barrier will have it's own Ce-MBC, if there is only a single EFO that operates all barriers, only wire a single barrier to the EFO input and use the EFO Sync feature in Rampart to program the operation

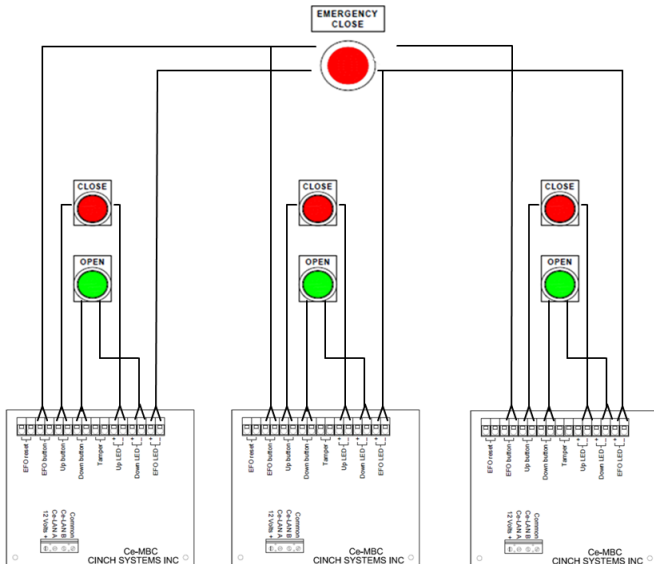

Note: If multiple barriers need to EFO with a single button press, only wire a single module to the switch and use the EFO Sync programming option in Rampart

Example: only Barrier 1 is wired to the EFO switch, in Rampart enter system programming and select Barrier 1 module, Sync/Interlock and EFO Sync Barrier 1 to Barrier 2 and Barrier 2 to Barrier 3

CeLAN Connection	
12VDC	In from Rampart or other 12VDC power supply
Bus A	Data bus A from Rampart
Bus B	Data bus B from Rampart
CMN	Common
Inputs	
Key Switch	Input from EFO reset switch
EFO PB	Input from EFO button
UP PB	Input from Up button
DWN PB	Input from Down button
Outputs	
Tamper	Not used
UP LED*	Output for UP status
DWN LED*	Output for Down status
EFO LED*	Output for EFO status

* Output rated for 6VDC

Programming:

Programming is accomplished using a touch screen connected to the Rampart data bus. The touch screen must be enrolled into the system in order for programming to commence.

Once installation and wiring is complete the manual barrier module must be enrolled in the Rampart system in order to complete programming.

Enrolling modules:

From the Rampart system touch screen enter system programming



Press the upper left followed by the upper right on the touch screen, a key board will display, enter a valid access code

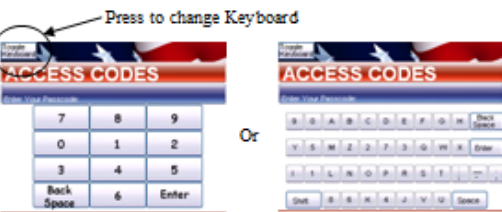

Default Installer Code: 12345

Once the access code is accepted select **CeLAN Devices** from the Main Menu then select **Enroll**

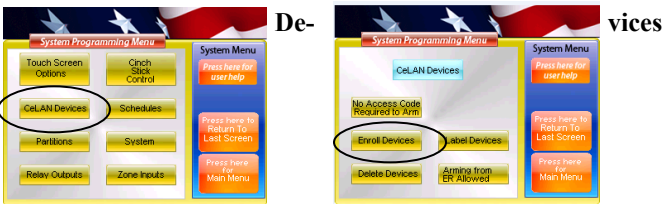

During this process all of the barrier control modules are enrolled into the Rampart control panel, when complete the touch screen will display "All Devices Enrolled"



Press Return to Last Screen to bring back the CeLAN Menu and select Label Devices\

Labeling CeLAN Devices:

Before programming devices make sure to assign text descriptors or labels to each device. This will make programming faster and easier. (add label —section)

Labeling CeLAN Devices:

Before programming devices make sure to assign text descriptors or labels to each device. This will make programming faster and easier. (add label —section)

Each module has two areas of programming that must be completed for proper operation

Barrier assignment - each module must be assigned to control a VBS module, during programming the system allows the user to select the VBS module to control

Priority setting - if the system to be programmed has master and remote control boxes and the master controller needs to be able to control the power of the remotes, this setting should be used

While in system programming enter the **CeLAN Menu** and **Label Devices**, using the Up/Down arrow find the MBC module to program.

All CeLAN modules are assigned a unique ID# for reference, in

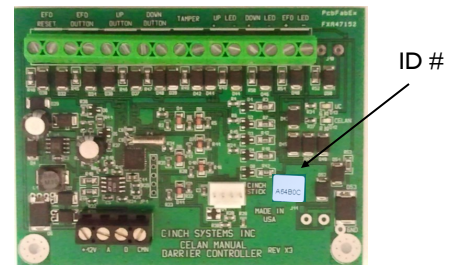

Find the MBC to program in the Label Device menu and press the Barrier Control Settings button



Press **Barrier Control Settings** to assign a barrier and set priority levels



Press **Select Barrier to Control** to assign a VBS Module the MBC will control



Use the **Up/Down** arrow to select the VBS Module the MBC will control

When complete press **Last Screen** button to set Priority Level

Priority level programming only needs to be done if an RCP is used on the system. Priority level setting tells the MBC to shut off when the Remote switch is set



Set to Level-1 for remote string 1
 Set to Level-2 for remote string 2
 Set to Level-0 for Master

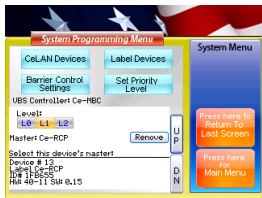

Use the **Up/Down** arrow to select the RCP Module the MBC will be assigned

When complete press **Last Screen** button to back up in programming to CeLAN Devices, Label Devices

Ce-VBS



Assign Barrier to MBC

MBC in remote 1

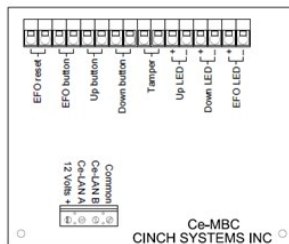

RCP in remote 1

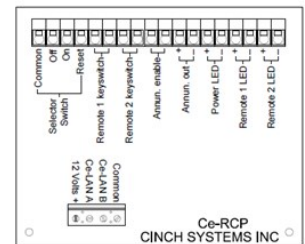

Assign MBC to RCP



Assign MBC to RCP Level-1



MBC - Manual Barrier Control

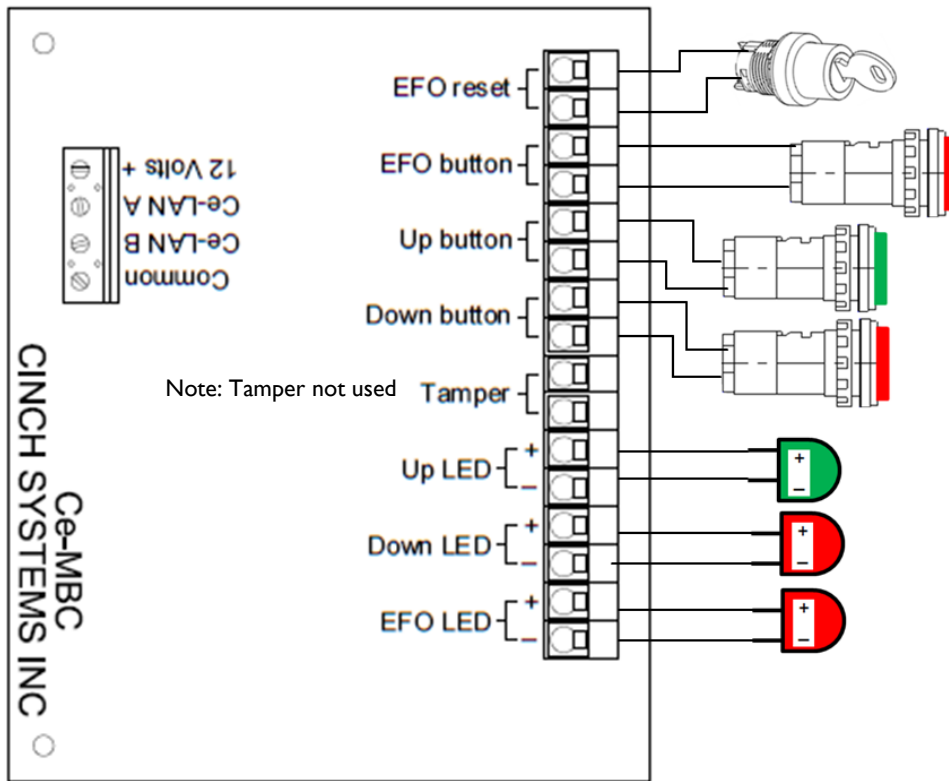

CeLAN Connection	
12VDC	In from Rampart or other 12VDC power supply
Bus A	Data bus A from Rampart
Bus B	Data bus B from Rampart
CMN	Common
Inputs	
Key Switch	Input from EFO reset switch
EFO PB	Input from EFO button
UP PB	Input from Up button
DWN PB	Input from Down button
Outputs	
Tamper	Not Used
UP LED*	Output for UP status
DWN LED*	Output for Down status
EFO LED*	Output for EFO status

* LEDs rated for 6VDC